

TYPHOON PUMP 2 UNLOADER ASSEMBLY

COPYRIGHT © 1995 OASIS CAR WASH SYSTEMS ALL RIGHTS RESERVED STANDARD TOLERANCES X.X = ± 0.063 X.XX = ± 0.015 X.XXX = ± 0.005 ANGLE = ± 0°30' FLATNESS = 0.05/FT WARNING! THE EXPORT OR REEXPORT OF THIS DRAWING OR A PRODUCT PRODUCED BY THIS DRAWING IS SUBJECT TO U.S. EXPORT ADMINISTRATION REGULATIONS AND OTHER APPLICABLE GOVERNMENTAL RESTRICTIONS OR REGULATIONS.	DIMENSIONS IN [] ARE MILLIMETERS	UNLESS OTHERWISE NOTED BREAK ALL SHARP EDGES AND CORNERS .015 AND 64 μIN SURFACE FINISH ALL OVER
	PROPRIETARY NOTICE THIS DOCUMENT CONTAINS CONFIDENTIAL AND TRADE SECRET INFORMATION, IS THE PROPERTY OF OASIS CAR WASH SYSTEMS, AND IS GIVEN TO THE RECEIVER IN CONFIDENCE. THE RECEIVER BY RECEPTION AND RETENTION OF THE DOCUMENT ACCEPTS THE DOCUMENT IN CONFIDENCE AND AGREES THAT, EXCEPT AS AUTHORIZED IN WRITING BY OASIS CAR WASH SYSTEMS, IT WILL: (1) NOT USE THE DOCUMENT OR ANY COPY THEREOF OF THE CONFIDENTIAL OR THE TRADE SECRET INFORMATION THEREIN; (2) NOT COPY THE DOCUMENT; (3) NOT DISCLOSE TO OTHERS EITHER THE DOCUMENT OR THE CONFIDENTIAL OR TRADE SECRET INFORMATION THEREIN; AND (4) UPON COMPLETION OF THE NEED TO RETAIN THE DOCUMENT, OR UPON DEMAND, RETURN THE DOCUMENT, ALL COPIES THEREOF, AND ALL MATERIAL COPIED THEREFROM.	
MATERIAL MATERIAL NO. _____ SIZE _____ HEAT TREAT _____ SURFACE _____ ASSEMBLY _____		

 OASIS		1909 EAST 12th STREET GALENA, KS 66739 TEL: (800) 892-3537 TEL: (620) 783-1355 FAX: (620) 783-5735 www.oasiscarwashsystems.com	
COMPONENT UNLOADER RETRO - FITTING KIT			
QTY/ASSY	DWG NO	REV	
	B12359	A-02	
SCALE	BY	DATE	SHT 1 OF 2
1:8			

REV.	DESCRIPTION	DATE	APVD
REVISIONS			

REV A-02

DWG NO B12359

A

ITEM NO.	PART NUMBER	DESCRIPTION	Exploded 1 View/QTY.
1	A-4490	VLV PRESS REG BRASS 1" UNLOADER PS	1
2	A-9506	ADPTR MJIC STL 2501-12-16	2
3	A-12382	RUN TEE 2605-16-16-16	1
4	A-3427	ADPTR SWVL NUT STL 6505-16-16	1
5	A-3422	ELB BT TUBE SWVL NUT LG 90DEG STL 6701-16	1

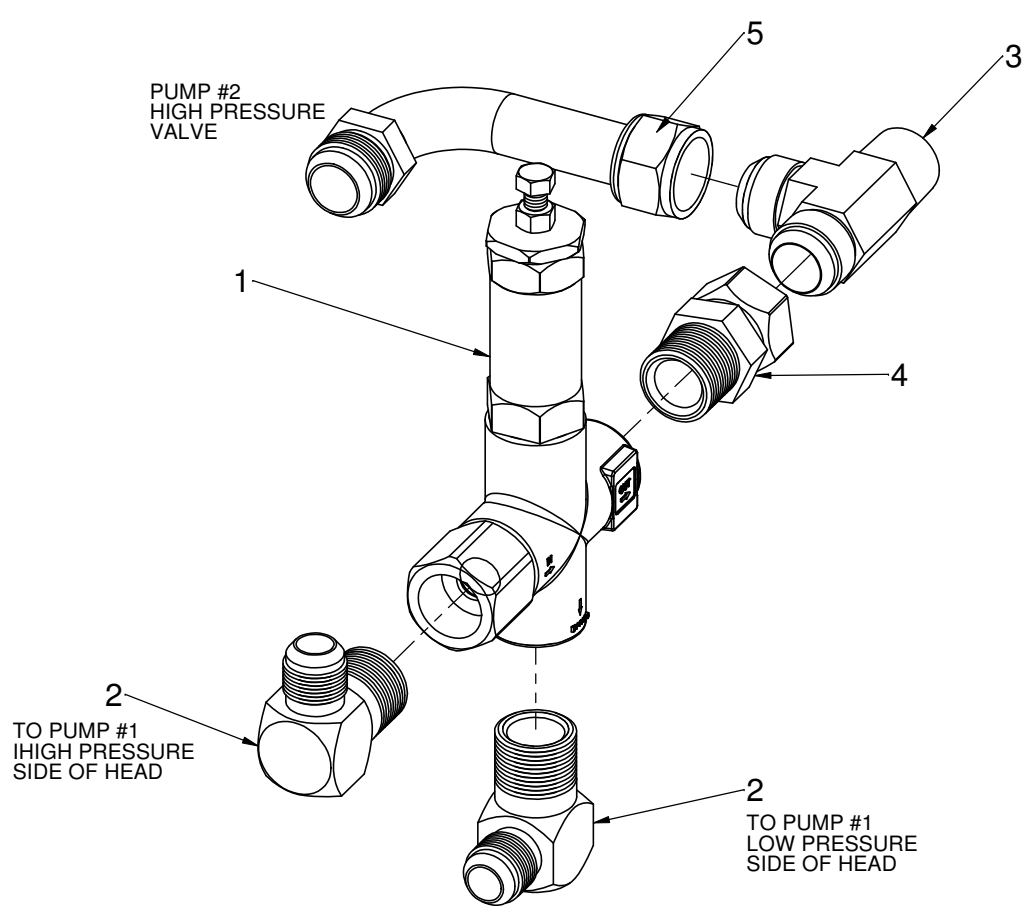

TYPHOON PUMP 2 UNLOADER ASSEMBLY

COPYRIGHT © 1995 OASIS CAR WASH SYSTEMS ALL RIGHTS RESERVED STANDARD TOLERANCES X.X = ± 0.063 X.XX = ± 0.015 X.XXX = ± 0.005 ANGLE = ± 0°30' FLATNESS = 0.05/FT	DIMENSIONS IN [] ARE MILLIMETERS	UNLESS OTHERWISE NOTED BREAK ALL SHARP EDGES AND CORNERS .015 AND 64 μIN SURFACE FINISH ALL OVER	 1909 EAST 12th STREET GALENA, KS 66739 TEL: (800) 892-3537 TEL: (620) 783-1355 FAX: (620) 783-5735 www.oasiscarwashsystems.com	
	PROPRIETARY NOTICE THIS DOCUMENT CONTAINS CONFIDENTIAL AND TRADE SECRET INFORMATION, IS THE PROPERTY OF OASIS CAR WASH SYSTEMS, AND IS GIVEN TO THE RECEIVER IN CONFIDENCE. THE RECEIVER BY RECEPTION AND RETENTION OF THE DOCUMENT ACCEPTS THE DOCUMENT IN CONFIDENCE AND AGREES THAT, EXCEPT AS AUTHORIZED IN WRITING BY OASIS CAR WASH SYSTEMS, IT WILL: (1) NOT USE THE DOCUMENT OR ANY COPY THEREOF OF THE CONFIDENTIAL OR THE TRADE SECRET INFORMATION THEREIN; (2) NOT COPY THE DOCUMENT; (3) NOT DISCLOSE TO OTHERS EITHER THE DOCUMENT OR THE CONFIDENTIAL OR TRADE SECRET INFORMATION THEREIN; AND (4) UPON COMPLETION OF THE NEED TO RETAIN THE DOCUMENT, OR UPON DEMAND, RETURN THE DOCUMENT, ALL COPIES THEREOF, AND ALL MATERIAL COPIED THEREFROM.			COMPONENT UNLOADER RETRO - FITTING KIT
WARNING! THE EXPORT OR REEXPORT OF THIS DRAWING OR A PRODUCT PRODUCED BY THIS DRAWING IS SUBJECT TO U.S. EXPORT ADMINISTRATION REGULATIONS AND OTHER APPLICABLE GOVERNMENTAL RESTRICTIONS OR REGULATIONS.	MATERIAL NO. HEAT TREAT ASSEMBLY	SIZE SURFACE	QTY/ASSY DWG NO B12359 SCALE 1:8	REV A-02 SHT 2 OF 2

REV **A-02**

DWG NO. **B12359**